



**CASAMBI
INSIDE**



Pending

▪ Description

CAS-UNI-NEMA-5P-010DA-RL-LX controller enables easy autonomous control and dimming of DALI, 0-10V and 1-10V devices (drivers, electronic ballasts, etc.). There is no need to use hubs, master devices or complex computer programs.

Communication is achieved by a meshed Bluetooth 4.0 or 5.0 network.

Each control unit stores information about its own configuration and also the configuration of the rest of controls installed in the same network. This provides the system with a high robustness level and also simplifies replacement of control units as programming them is not required.

Configuration and control can be done from a mobile phone or tablet using the free CASAMBI APP (available for iOS and Android). The networks work autonomously once configured. Remote control of the installation is also possible through the cloud by use of an internet connected device with Casambi App set up as gateway.

Main use is control of outdoor lighting applications. It is provided with an IP66 UV resistant enclosure. Hydrophobic vent is incorporated to prevent condensation.

Electrical connection and mechanical fixing are done through a standard NEMA socket (ANSI 136.41) without tools, by twist and lock.

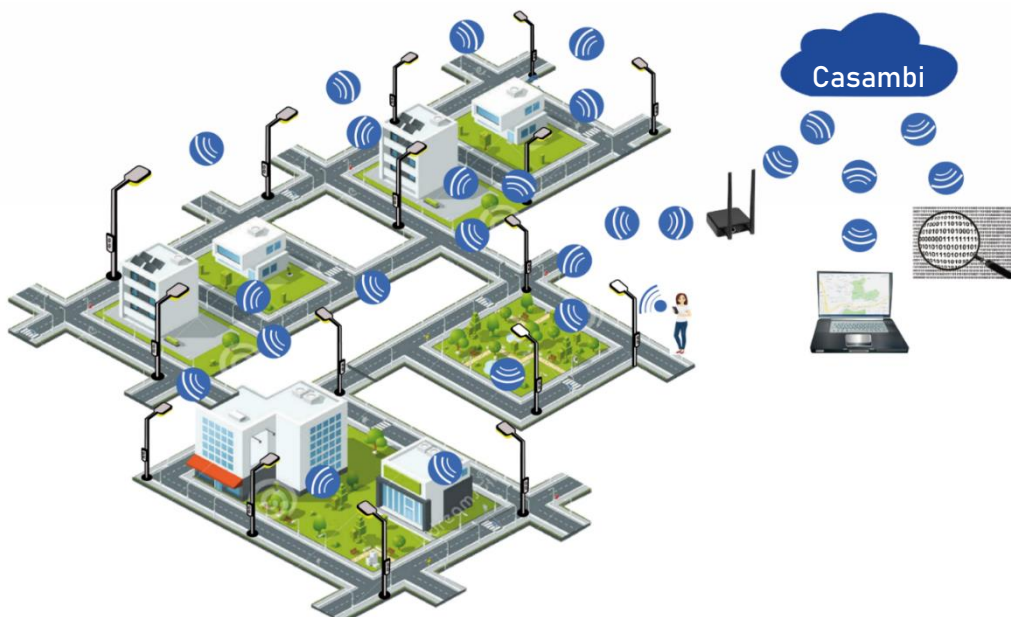

■ Operation

By use of CASAMBI APP it is possible to group the luminaries by streets or areas, set dimming levels based on the time, schedule special events for specific dates, etc.

Different types of nets can be selected (with different communication speeds and ranges). Range between controllers in outdoors without obstacles is up to 70m in Balanced BLE4 type nets, and can be over 200m in BLE5 Long range type nets. Adding the controllers to a net must be done with a mobile phone or tablet within range of each unit. For further installation setup and programming it is only necessary to be within the range of one of the controllers. Because it is a mesh type network, controllers communicate with each other until the information reaches the controller for which it is intended, even if it is located far away.

Up to 250 controllers (or other Casambi devices) can be supported per network. Depending on the network type (communication speed) and the required data traffic this number may have to be reduced to ensure a fluent behaviour. One installation can have unlimited number of networks which can be grouped together in one Site. Through the site we can control different networks simultaneously (for this each network must have access to Internet through a gateway and have gateway function enabled).

Communication security is provided by encrypted messages. It is possible to set different levels of access and configuration permissions. Network configuration information can optionally be stored in CASAMBI cloud and recovered if necessary. Several restoration points can be created. When a controller receives a firmware update, it will automatically be retransmitted to the other controllers in the network.

Diverse operating modes are possible (on/off, dimming 0-100%, circadian control, tunable white, RGB, RGBW, etc.).

Different dimming signal profiles can be configured to match the luminaire driver/ballast requirements (see profile list), these include several DALI as well as 0-10V and Relay. The incorporated DALI power supply can be deactivated/activated with Casambi App.

It is compatible with any other devices from other manufacturers which also incorporate CASAMBI inside and CASAMBI Ready products like luminaires, presence sensors, relays, actuators, push buttons, etc.

CAS-UNI-NEMA-5P-010DA-RL-LX features a light sensor which can be configured in Casambi App to set specific illuminance levels for energy saving, or used in daylight controlled basic scenes for switching the lights on/off. Also an external DALI-2 motion/light sensor can be connected to the DALI bus and will appear as a Casambi sensor in the App (with some specific profiles).

The internal relay controls the LOUT output and will switch it on automatically when the dimming level is greater than 0. However, some specific profiles allow independent control of the relay. The internal temperature of the unit can be monitored in the App.

CAS-UNI-NEMA-5P-010DA-RL-LX is IoT ready. It can receive information provided by a DALI D4i driver or ballast (power consumption, working hours, accumulated energy consumption, temperature, etc.) which can be sent to Casambi cloud through a Gateway device with internet connection and Casambi App set up as gateway. Access to this big data to exploit this information is possible through API and JSON protocol.

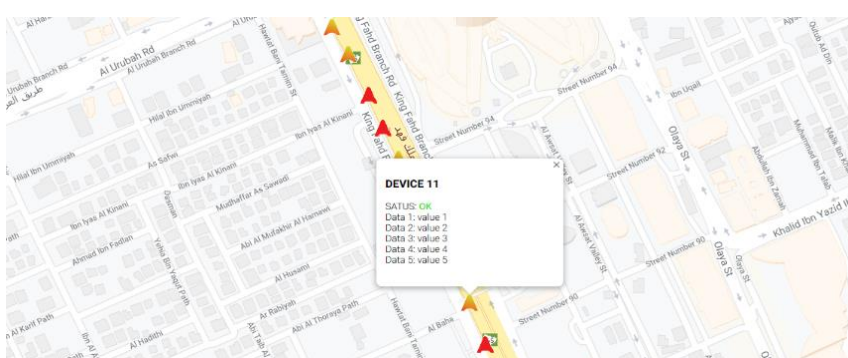

■ Technical data

CAS-UNI-NEMA-5P-010DA-RL-LX	
Nominal line voltage	110-277Vac
Input voltage range	85-305Vac
Input current	≤ 23mA
Frequency	47-63Hz
Power consumption standby	<0,8W@230Vac (Unconnected DALI/0-10V dimming output, LOUT on)
Power consumption	<1,25W @230Vac (One DALI device connected or 2mA 0-10V)
Output control interface	DALI (active or passive) / 0-10V, according to profile type.
Integrated DALI BUS voltage source	16VDC (isolated from mains)
DALI output current (*)	45mA rated. 20mA Guaranteed DALI current / 60mA max.
0-10V voltage range/max current	0,2-10V/8mA source. 0,4-10V/10mA sink. (0,2-10V@0-5mA sink)
Dimming range	0-100%
LOUT max. current	10A with resistive load / 5A with Electronic ballasts or LED drivers
Light sensor range	20-1500Lx
RF communication interface	Bluetooth 4.0 or 5.0 Low energy (BLE)
RF communication protocol	Casambi
RF spectrum	2402–2483 MHz
RF network	Self-healing, frequency-hopping, spread spectrum mesh technology
Maximum transmission power	+7 dBm
Wireless class	Class 2
Data security	AES128 bit encryption + elliptical cryptography
Firmware update	OTA (Over the air)
Time/date update	Internal counter. Updatable from Casambi gateway or APP or by use of Timer-Casambi device, after power loss in all the net.
Protections	Line permanent over voltage, line surge over voltage, over temperature.
Temperature monitoring	Internal temperature is displayed in Casambi App
Operating temperature range	-30° to +60°C
Dimensions	Diameter 88mm. Height 63mm
Weight	198gr. (Carton box included)
Enclosure material	PC with anti-UV treatment
Enclosure isolation type	Class II. Reinforced isolation 
IP	66
IK	09
Connector	NEMA 5P (ANSI C136.41)
Standards	EN 61347-1:2016, EN 61347-2-11:2003, EN 55015:2013, EN 61547:2011, EN 61000-3-2, EN 61000-3-3, EN 301489-1, EN 301489-17, UL773, FCC Part 15
DALI standards	IEC 62386 part 101, 103, 351. Part 303, 304 (supports DALI-2 Light and motion Sensors. Part 251-253 (supports luminaire, energy and diagnosis data)
Directives	(LVD) 2014/35/UE, (EMC) 2014/30/UE, (RED) 2014/53/UE, (RoHS) 2011/65/UE, (REACH) 1907/2006.

(*) When the integrated DALI Bus Power Supply of 60mA max is enabled, the maximum bus power supply current provided by other components in the DALI bus shall be at most 190mA. The node can source the rated DALI current, but is DALI certified for the stated maximum and guaranteed currents.

■ **Standard Profiles (fixtures)**

PROFILE	DESCRIPTION
010 Linear	0-10V output. Linear dimming curve. LOUT switches on when dimming level >0
010 Linear + iRelay	0-10V output & Relay. Linear dimming curve. Independent toggle switch control for the internal relay that switches the Live output (LOUT). (Long press on the icon in the App for toggle switch to show up)
RELAY	Relay. Toggle switch for the internal relay that switches the Live output (LOUT).
DALI Lin* BC (No LX sensor)	DALI Broadcast. Linear dimming curve. Factory default profile. LOUT switches on when dimming level >0. Without light sensor.
DALI Lin* Broadcast	DALI Broadcast. Linear dimming curve. LOUT switches on when dimming level >0
DALI Lin* BC + iRelay	DALI Broadcast & Relay. Linear dimming curve. LOUT has independent control by a toggle switch (cannot be switched ON/OFF by tapping on the icon). (Long press on the icon in the App for toggle switch to show up)
DALI Lin* BC +Ext. Sensors	DALI Broadcast. Linear dimming curve. External DALI-2 motion and light sensor connected to the DALI bus will appear as a Casambi sensor in the App. The Internal light sensor of the node is disabled. LOUT switches on when dimming level >0.
DALI Lin* BC +Ext. Presence	DALI Broadcast. Linear dimming curve. A compatible External DALI-2 motion sensor connected to the DALI bus will appear as a Casambi sensor in the App. LOUT switches on when dimming level >0.
DALI Log BC +Ext. Presence	DALI Broadcast. Logarithmic dimming curve. A compatible External DALI-2 motion sensor connected to the DALI bus will appear as a Casambi sensor in the App. LOUT switches on when dimming level >0.
DALI Lin* (4xGroup)	DALI Broadcast 4xGroup. Linear dimming curve. LOUT switches on when dimming level >0. Controls DALI groups G0-G3.
DALI Lin* DT6 TW Warm-Cool SA	DALI DT6 Tunable white. Generic Warm-Cool slider (no CCT value data). Linear dimming curve. Uses addresses A0, A1. Automatic DALI addressing. LOUT switches on when dimming level >0.
DALI Lin* DT6 TW 3-5K SA	DALI DT6 Tunable white. 3000K-5000K. Linear dimming curve. Uses addresses A0, A1. Automatic DALI addressing. LOUT switches on when dimming level >0.
DALI Lin* DT6 RGB SA	DALI DT6 RGB. Linear dimming curve. Uses addresses A0-A2. Automatic DALI addressing. LOUT switches on when dimming level >0
DALI Lin* DT6 RGB/W SA	DALI DT6 RGB/W. Linear dimming curve. White/Colour balance control. Uses addresses A0-A3. Automatic DALI addressing. LOUT switches on when dimming level >0
DALI Lin* DT6 2xDIM SA	DALI DT6 2xDimmers. Linear dimming curve. Individual slider levels are overwritten when dimmed by sliding on the App icon. Uses addresses A0, A1. Automatic DALI addressing. LOUT switches on when dimming level >0
DALI Lin* DT6 2xDIM SA +Ext.Presence	DALI DT6 2xDimmers. Linear dimming curve. A compatible External DALI-2 motion sensor connected to the DALI bus will appear as a Casambi sensor in the App. Individual slider levels are overwritten when dimmed by sliding on the App icon. Uses addresses A0, A1. Automatic DALI addressing. LOUT switches on when dimming level >0.
DALI Lin* DT6 3xDIM SA	DALI DT6 3xDimmers. Linear dimming curve. Individual slider levels are overwritten when dimmed by sliding on the App icon. Uses addresses A0-A2. Automatic DALI addressing. LOUT switches on when dimming level >0.
DALI Lin* DT6 4xDIM SA	DALI DT6 4xDimmers. Linear dimming curve. Individual slider levels are overwritten when dimmed by sliding on the App icon. Uses addresses A0-A3. Automatic DALI addressing. LOUT switches on when dimming level >0.
DALI Lin* DT6 5xDIM SA	DALI DT6 5xDimmers. Linear dimming curve. Individual slider levels are overwritten when dimmed by sliding on the App icon. Uses addresses A0-A4. Automatic DALI addressing. LOUT switches on when dimming level >0.
DALI Lin* DT6 6xDIM SA	DALI DT6 6xDimmers. Linear dimming curve. Individual slider levels are overwritten when dimmed by sliding on the App icon. Uses addresses A0-A5. Automatic DALI addressing. LOUT switches on when dimming level >0.
DALI Lin* DT6 7xDIM SA	DALI DT6 7xDimmers. Linear dimming curve. Individual slider levels are overwritten when dimmed by sliding on the App icon. Uses addresses A0-A6. Automatic DALI addressing. LOUT switches on when dimming level >0.
DALI Lin* DT6 8xDIM SA	DALI DT6 8xDimmers. Linear dimming curve. Individual slider levels are overwritten when dimmed by sliding on the App icon. Uses addresses A0-A7. Automatic DALI addressing. LOUT switches on when dimming level >0.
DALI Lin* DT8 TW 3-5K BC	DALI-2 DT8 Tunable white. 3000K-5000K. Broadcast. Linear dimming curve. LOUT switches on when dimming level >0.
DALI Lin* DT8 RGB/W BC	DALI-2 DT8 RGB/W Broadcast. Linear dimming curve. White/Colour balance slider. LOUT switches on when dimming level >0

DALI Lin+ DT8 XY/W BC	DALI-2 DT8 XY/W Broadcast. Linear dimming curve. Colour control by X,Y coordinates. LOUT switches on when dimming level >0
------------------------------	---

Other profiles available on request.

The updated profiles list is available at the product web page in the "Adjuntos" section: [LINK](#)

DALI type profiles of CAS-UNI-NEMA-5P-010DA-RL-LX have their internal DALI power supply activated by default.

It is possible to deactivate it by changing the PARAMETERS setting of the luminaire in the App:

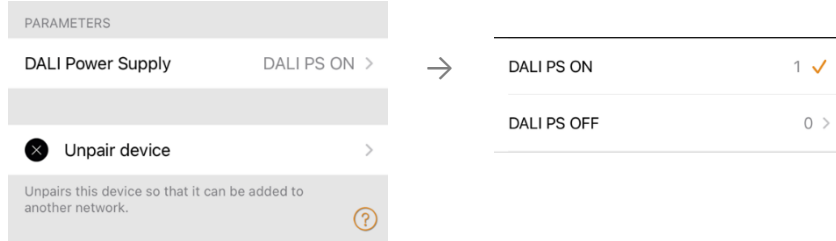

■ Wiring diagram

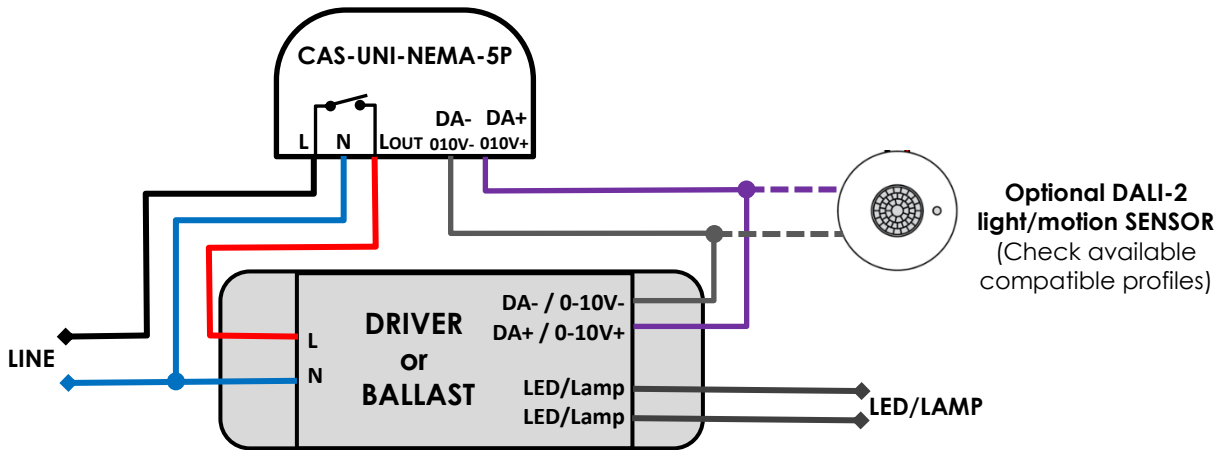

Note: The internal relay is normally closed (NC). When the controller is unpowered, LOUT is connected to L.

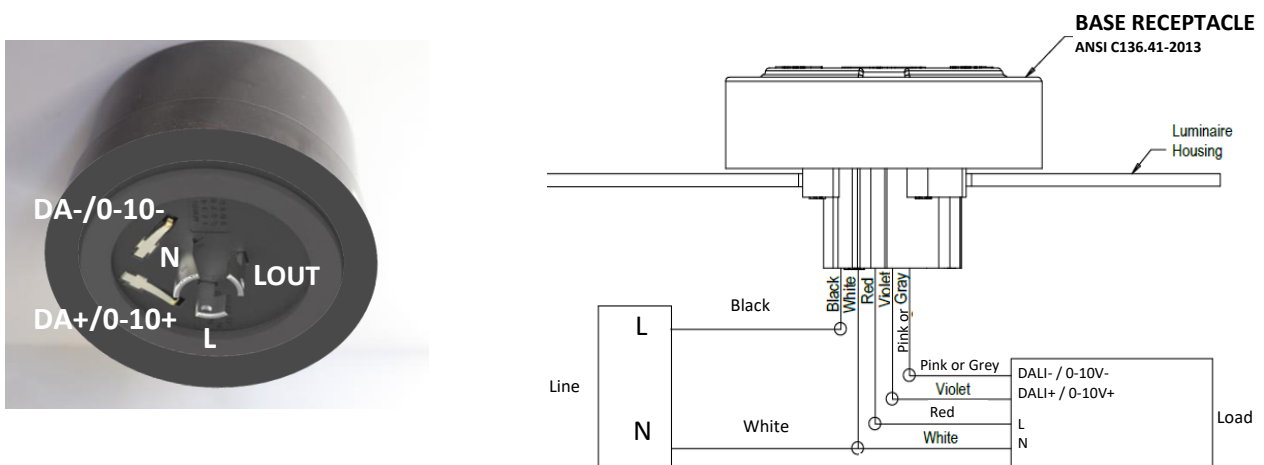

OLFER and CASAMBI are registered trademarks. We reserve the right to make any changes without notice in the information reflected herein, not being liable for any harm that this may cause. This information is relative to the current product version. Due to firmware, software or hardware improvements, it is possible that previous product versions can lack some of the features indicated in this datasheet.